

SP 7.1 Determine the flexibility influence coefficients for the beam-mass system shown. Include two degrees of freedom (vertical translation and in-plane rotation).

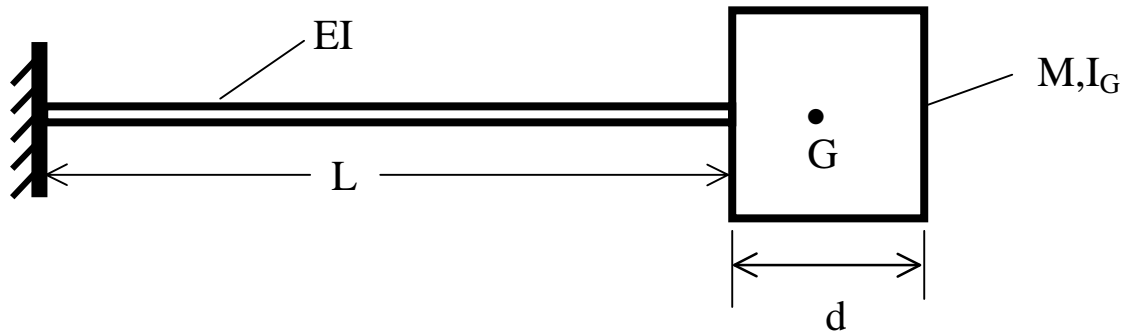

SP 10.1) Solve problem 7.47 with $U(t) = u_0 \sin \omega t$ and $\omega = 4.5\sqrt{EI/mH^3}$.

SP 10.2) Consider problem 7.47 with $U(t) = u_0 \sin \omega t$ and determine the frequency response function α_{jk} . Plot α_{jk} as a function of the dimensionless frequency $\omega/\sqrt{EI/mH^3}$.

SP 11.1 Consider the damped 2 DOF system shown. Determine

- the undamped natural frequencies and normal modes,
- the damped frequencies, damping ratios, and complex modes,
- the damped frequencies and the damping ratios using the diagonal part of $[C] = [u]^T [c] [u]$, where $[u]$ is the undamped modal matrix.

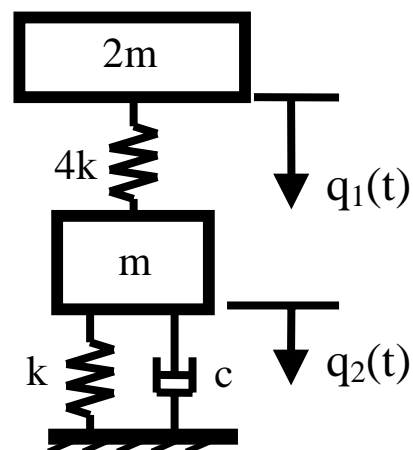

$$c = 2\sqrt{km}$$