



# **Landmark Center Rotary Path and Roadway Redesign**

## *Executive Summary*

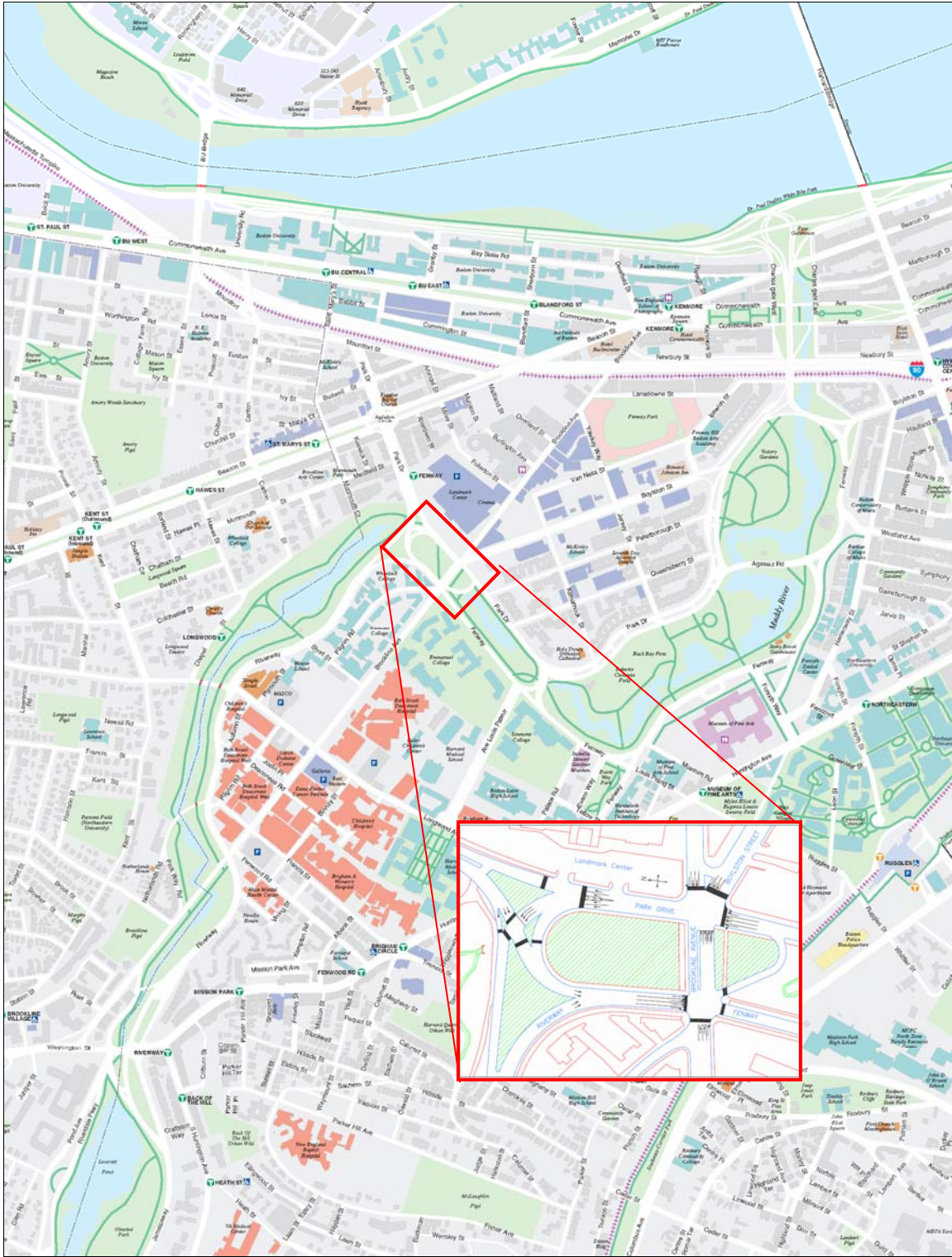
**Team Members:**

PM: Will Miller  
Jeff Haelle  
Nick Gaboury  
John Tamburrini  
Jon Simmons

# Table of Contents

	Page
<b>Locus Map</b> .....	2
<b>Introduction</b> .....	3
<b>Current Problems with the Rotary</b> .....	4
<b>Origin-Destination Data</b> .....	6
<b>Future Developments Analysis</b> .....	8
<b>MRA’s Proposed Design</b> .....	8
<b>The Sandal</b> .....	8
<b>The Riverway Merge and Intersection Analysis</b> .....	9
<b>Existing Conditions:</b> .....	9
<b>Improvements</b> .....	11
<b>Two-way traffic for Riverway:</b> .....	11
<b>Lengthening Approach:</b> .....	11
<b>Signalized Merge:</b> .....	11
<b>Conclusion:</b> .....	11
<b>Removal of the All-Ped Phase</b> .....	11
<b>Pedestrians waiting for the all-ped phase:</b> .....	12
<b>Data &amp; Analysis:</b> .....	12
<b>Solution:</b> .....	12
<b>Pedestrian Paths and Mid-Park Bridge</b> .....	13
<b>Riverway Bridge Feasibility</b> .....	15
<b>Current Bike and Pedestrian paths</b> .....	16
<b>Bike and Pedestrian path dimensions</b> .....	19
<b>Roadway elevations and profiles</b> .....	19
<b>Cross Section:</b> .....	21
<b>Conclusion:</b> .....	22
<b>Cost Estimate</b> .....	22
<b>Conclusion</b> .....	25

# Locus Map



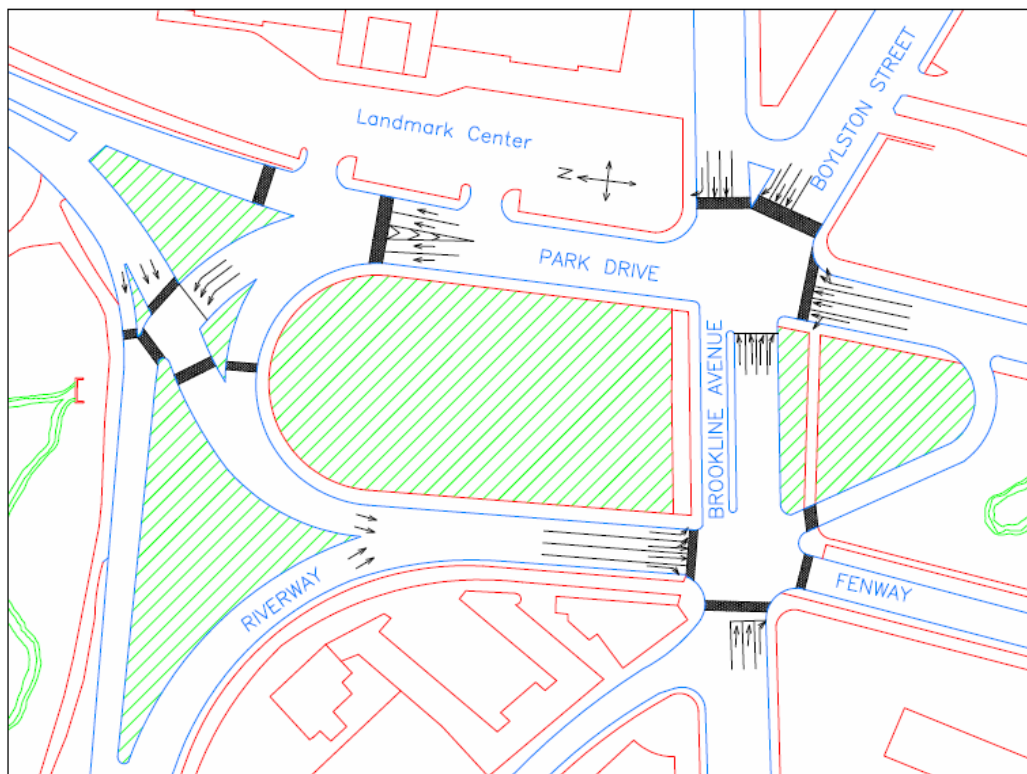
## Introduction

Currently, the Landmark Center Rotary causes significant traffic problems while essentially creating a break in Olmsted's Emerald Necklace. With the recent allocation of 55 million dollars towards vehicular and pedestrian improvements in the Fenway area and the current project being undertaken by the Army Corp of Engineers to daylight the Muddy River, a unique opportunity to greatly improve both the traffic flow as well as the functionality of the park has presented itself.

Over the past few months, we have collected extensive data on the Landmark Center Rotary (also known as the Sears Rotary). Traffic counts at each intersection as well as Origin-Destination counts were done for both AM and PM peak periods. This data has allowed us to determine the feasibility of several alternatives (both new and old) to the current rotary.

Our project was designed to meet the following objectives:

- Increasing pedestrian and bicyclist access to the Park
- Improving Traffic Flow
- Reconnect the park to Frederick Olmsted's Emerald Necklace
- Improving bicyclist and pedestrian paths along the Muddy River



Current Layout

## Current Problems with the Rotary

The rotary has several main problematic areas shown below:



(\* Note that for discussion purposes, the streets running East-West are Brookline Ave, Boylston St, and part of The Riverway while Park Drive and Fenway run North-South.)

1. Where The Riverway merges before the Brookline Ave intersection is particularly bad, especially during heavy traffic flow. The majority of cars coming from the northwest side of the rotary either want to continue down The Fenway or make a right onto Brookline West Bound, and the majority of cars coming from The Riverway into the rotary want to make a left at the Brookline Ave. intersection. This results in a significant number of cars from each approach attempting to cross one or two lanes to continue through the intersection in the desired direction. With too short a distance between the intersection and the merge point, cars often become blocked by queues waiting to discharge, resulting in cars not being able to fill in a spot in their lane's queue. This weave problem greatly decreases the capacity of the intersection and is very hectic for drivers (see Image 1). This problem is further described in section titled, "The Riverway Merge and intersection."
2. Pedestrians and bicyclists coming from the paths upriver of the park currently have to make a four stage crossing of The Riverway. This is incredibly tedious for a pedestrian trying to make a legal crossing, essentially creating a break in Olmsted's paths running through the parks to the North and South of the Landmark Center Park. Also, the current roadway layout covers a significant distance of the Muddy River, which will result in a very wide (and very expensive) bridge in the upcoming Muddy River Day-Lighting project. Subsequently, a wide bridge would mean a very long underpass which would be an undesirable characteristic for the pedestrian path (further discussed in the "Feasibility of pedestrian walkway under The Riverway Bridge" memo).

3. Queues in the section of Brookline Ave between The Fenway and Park Drive often become backed up enough to interfere with the flow of traffic in the Park Drive/Boylston/Brookline intersection as well as the Riverway/Brookline/Fenway intersection. On the West bound side of this section of Brookline Ave, these backups are often a result of the all pedestrian phase being called by the push buttons at the crossings of Brookline and The Riverway.
4. Pedestrian “interior” crossings (meaning the crossings of Brookline Ave from one park to the other) at the Riverway/Brookline/Fenway intersection are inadequate, and force pedestrians to make multiple stage crossings when single stage crossings could work. Currently, an all pedestrian phase exists, yet there is no crosswalk across the western side of the intersection, so pedestrians and bicyclists wishing to continue down the Muddy River paths are expected to make three street crossings where only one is needed.
5. The same problem exists at the Brookline/Park Drive/Boylston intersection. Pedestrians and bicyclists wishing to continue down the Muddy River paths are currently expected to make a four stage crossing (across Park Drive, then Brookline Ave, then Boylston, then Park Drive again) where a one stage crossing (across Brookline Ave) would be ideal.



Image 1

### Origin-Destination Data



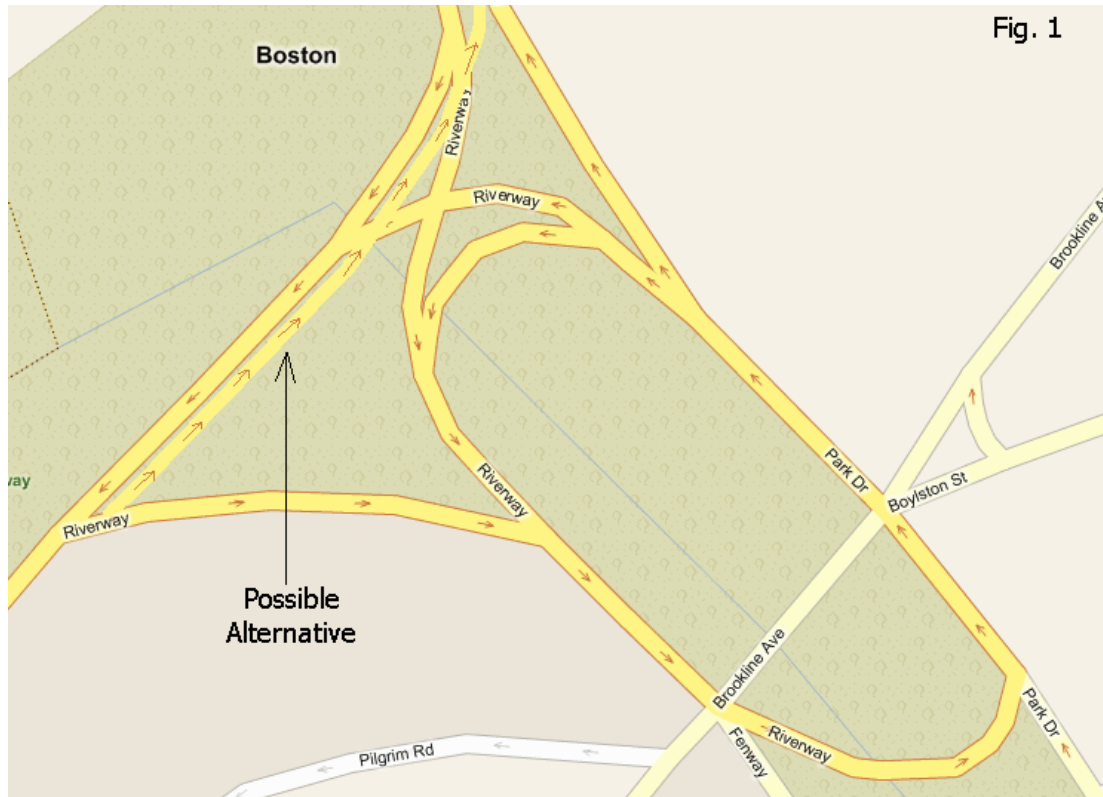
Image 2 - six main routes into the rotary

#### Six main routes into the rotary

- The Riverway
- Brookline Ave EB
- Brookline Ave WB
- Park Drive SB
- Park Drive NB
- Boylston

One of our main objectives in the redesign of the Sears Rotary is to improve traffic circulation while decreasing its effect on pedestrian and bicyclist activity in and around the park. In order to further understand the traffic demands on the rotary, it was necessary to do traffic counts for each intersection, as well as what we call ‘Origin-Destination’ counts. These counts were necessary since in the rotary, it is not always clear by doing standard traffic counts where each car entered and left the rotary. For example, in evaluating whether it is beneficial to connect The Riverway East Bound with Park Drive North Bound (depiction of example shown in figure 1) it is very important to understand the number of cars wishing to make this trip. Since these cars currently have

to go through multiple intersections to take this route it would be impossible to get a quantitative assessment of this demand using only the standard traffic counting methods.



Example Alternative

In order to get accurate results for the origin-destination counts, we needed a reliable way to track cars where they entered and left the intersection. A simple and effective way of doing this is to take a random sample of cars and watch their movement through the intersection. We decided to track all red cars entering the rotary from every possible origin and record where that car left the rotary. We were able to get origin-destination counts over a four day period starting on January 29<sup>th</sup>. Counts for the AM were conducted between 8:15 and 9:30 while counts for the PM were conducted between 4:00 and 5:30. During the counting periods, queues were observed to have grown and shrunk sporadically.

Approximately 200 cars during the AM peak and 200 cars during the PM peak were tracked for each origin and their destinations were recorded. This data was then converted into a percentage for each destination per origin. This percentage, combined with the raw traffic counts per intersection, was converted into vehicles per hour making the 31 different possible routes through the intersection.

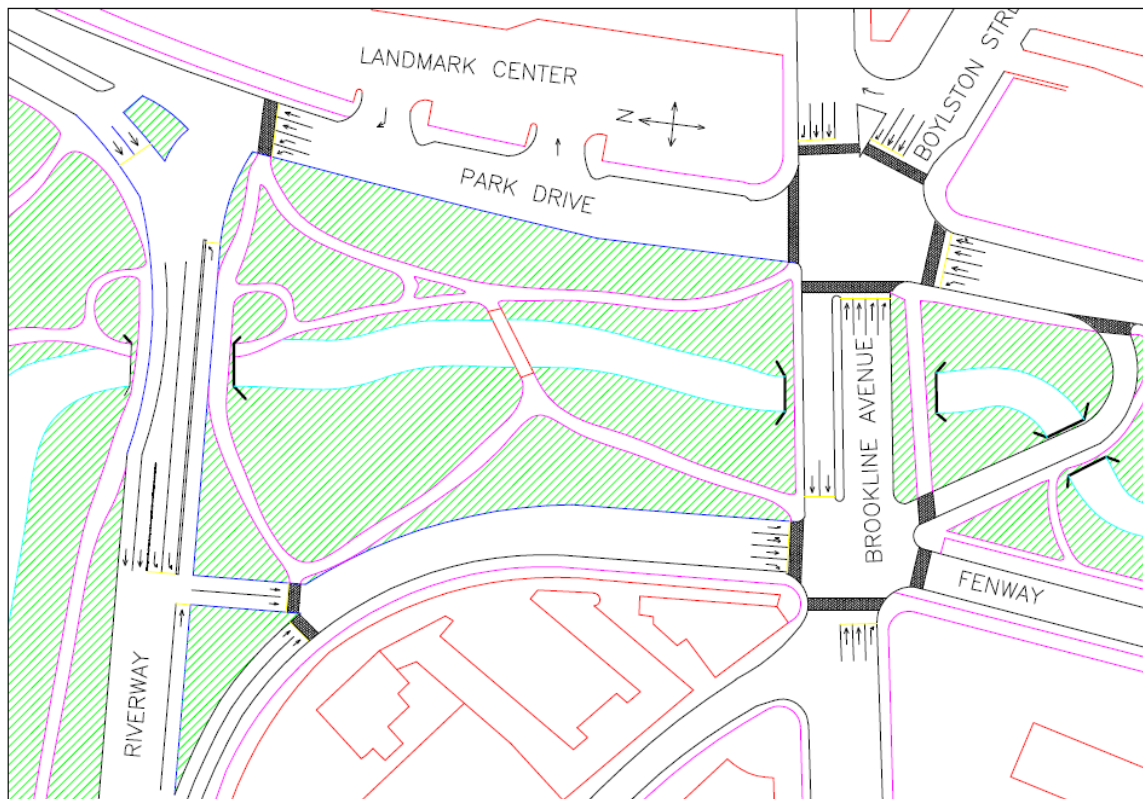


## Future Developments Analysis

We needed to account for future development in the Landmark Center Rotary area which would result in an increase in the amount of traffic. Some of the impending developments that will affect traffic in the rotary are the Trinity apartments and parking, a new Red Sox parking garage, and the day lighting of the Muddy River. A Synchro model was used to analyze the intersections with future traffic volumes, and the proposed design is more than sufficient for the additional expected traffic.

## MRA's Proposed Design

### The Sandal



To alleviate the merging problem on The Riverway, it is necessary to either allow for more room to merge (increasing the distance between the merge and the intersection), or to control the traffic entering the weave with a signal. The Sandal, utilizes a combination of these two solutions. First, the distance between the merge and the intersection has been increased significantly. Second, traffic entering the weave will be controlled by signals with short cycle lengths for a high level of service. More details on this point are explained on page 14 in “The Riverway Merge and Intersection Analysis.”

A signalized intersection would also allow for crosswalks to be installed where the two legs of The Riverway heading towards the Fenway merge, allowing pedestrians and bicyclists to easily cross. Currently, pedestrians trying to make this crossing are expected to walk down to Brookline Ave to cross. With these crosswalks installed, students and other residents near Wheelock College will have a safe and much more direct way to walk to the Landmark Center and the Fenway T stop. In order to avoid any negative affects these crosswalks would have on the traffic flow, the walk signals could run concurrently with the traffic light. With a cycle length for the intersection of 90 seconds, this could be done with very little delay for the pedestrians. Image 2 shows pedestrians attempting to make the crossing without any protection from oncoming traffic.



Image 2

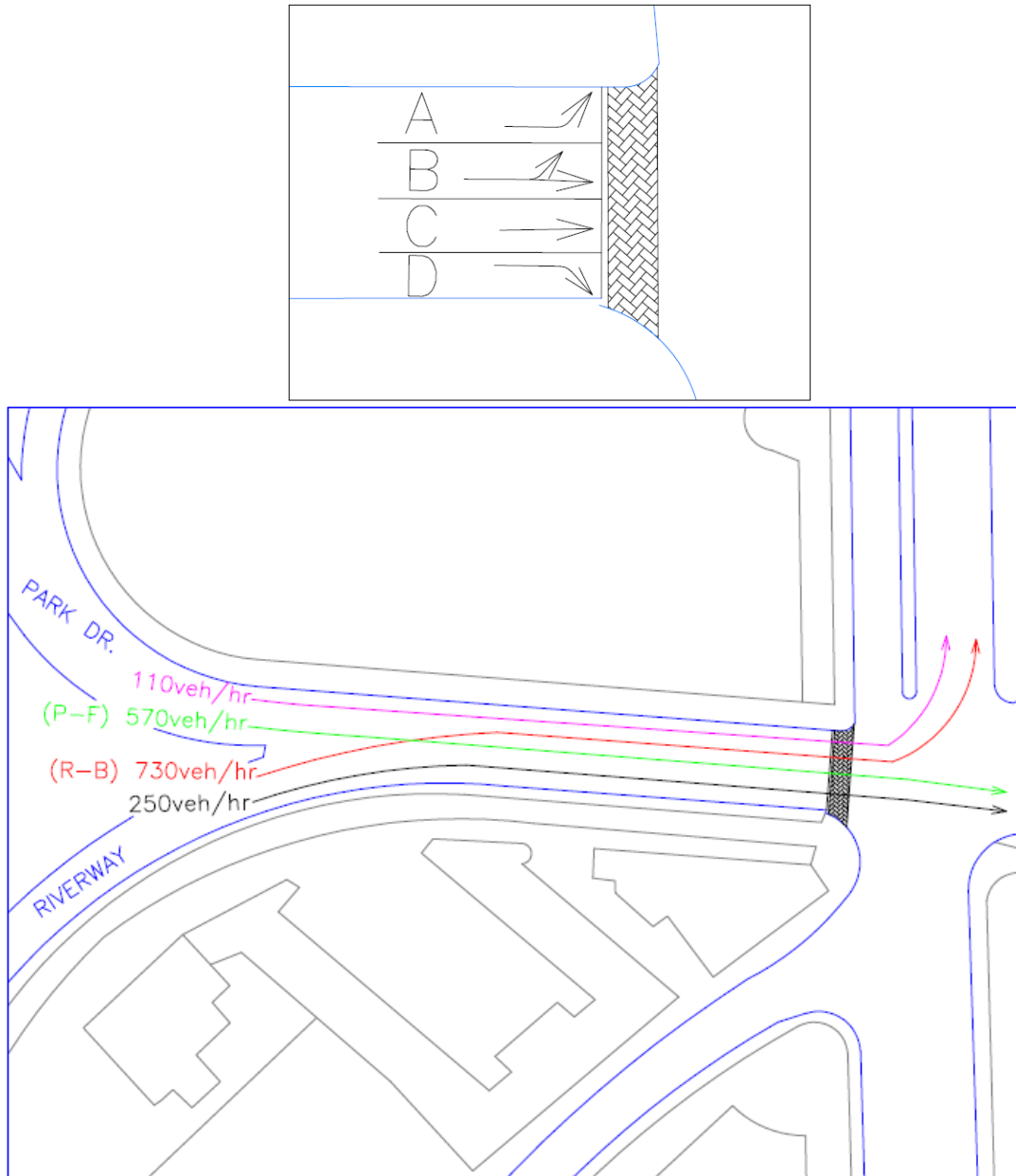
Pedestrians and bicyclists trying to follow the paths along the Muddy River through the rotary would also greatly benefit from this alternative. The four stage crossing of The Riverway that currently exists would be changed to either an all ped phase, four lane crossing or even could travel under the Riverway Bridge on a pedestrian walkway as discussed in the “Pedestrian Underpass” section. The four lane crossing would drastically reduce the delay for pedestrians, and would most likely re-open the crossing as a realistic connection between the Muddy River Paths.

Making a direct connection between The Riverway and Park Drive North Bound would greatly reduce the distance and delay for vehicles wishing to continue up Park Drive from the Riverway. It would also remove 125 veh/hr from the two Brookline Ave Intersections, which are currently oversaturated during peak flows. This in itself is a major improvement for the rotary.

## **The Riverway Merge and Intersection Analysis**

### **Existing Conditions:**

Shown below are the lanes that make up the Riverway approach. The lanes have been labeled A, B, C, & D and these labels will be referred to throughout the analysis.



The graphic above is an illustration of how the weave affects the approach. Sometimes the P-F traffic stream blocks the merge point, starving Lane A. Other times, the R-B stream blocks the merge point, starving Lane C. In either case, the result is poor lane utilization, thus lowering the intersection's capacity. The table below shows the effects of the blocked state on the approach.

Green  
Ratio:  
(g/C)= 0.4

Lane	Ideal "s" (veh/hr)	Blocked State (veh/hr)	Lane Utilization (veh/hr)	Unblocked Capacity (veh/hr)	Blocked Capacity (veh/hr)
A	1400	1000	0.71	560	400
B	1400	1400	1.00	560	560
C	1750	1250	0.71	700	500

**Improvements**

**Two-way traffic for Riverway:**

In The Sandal plan, Riverway is redesigned to carry two-way traffic. This removes vehicles that would be using the Riverway approach. By removing them there will be a reduced demand for the approach.

**Lengthening Approach:**

The current situation only allows for 300' of queue space, the Sandal plan lengthens the available queue length to 400'. The total of 16 vehicles in queue that the Sandal plan can handle is the same amount that are able to pass through the intersection with the green time Riverway is given.

**Signalized Merge:**

The Sandal plan now controls the merge by a traffic signal. The signal will give each roadway their own time to proceed to the Riverway Approach and it will allow for safer crossing for pedestrians. The signals will also be coordinated so that neither weaving movement blocks the other.

**Conclusion:**

The weaving problem creates a situation that is both unsafe and ineffective. Once the weaving problem is solved there won't be the blocked state which occurs during almost every cycle during the a.m. peak period. The elimination of the blocking will in turn increase the capacity per lane for the Approach.

**Removal of the All-Ped Phase**

The intersection of Brookline Ave and Fenway has an all pedestrian phase that can be called by people crossing either Brookline Ave or the Fenway. This intersection is shown to the right in figure 1:

When the all-ped is activated cars get backed-up on Brookline Ave West Bound. During peak periods, this area can get backed up into the Boylston-Brookline-Park Drive Intersection. This causes

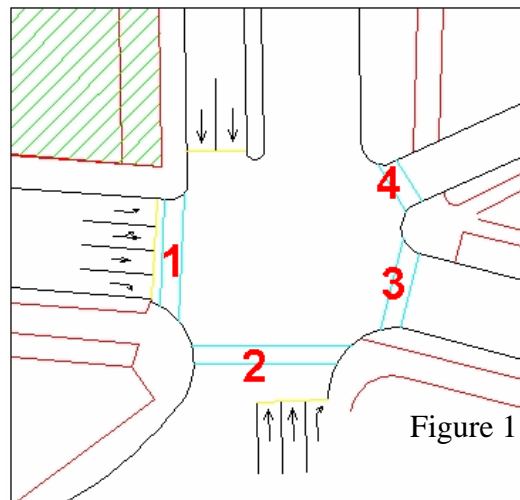


Figure 1

congestion due to intersection blocking. Our objective in studying this intersection was to find out if the all-ped phase is needed, and if it's elimination could help the intersection's capacity.

### **Pedestrians waiting for the all-ped phase:**

It was observed that pedestrians crossed Brookline Ave during the Riverway-Fenway green time and they crossed Fenway and the jughandle during the Brookline Ave green time regardless of whether or not the ped-phase was called. This leads us to believe that the all-ped isn't needed, and this will be addressed in the solution. Below, the phase sequence is shown in figure 2:

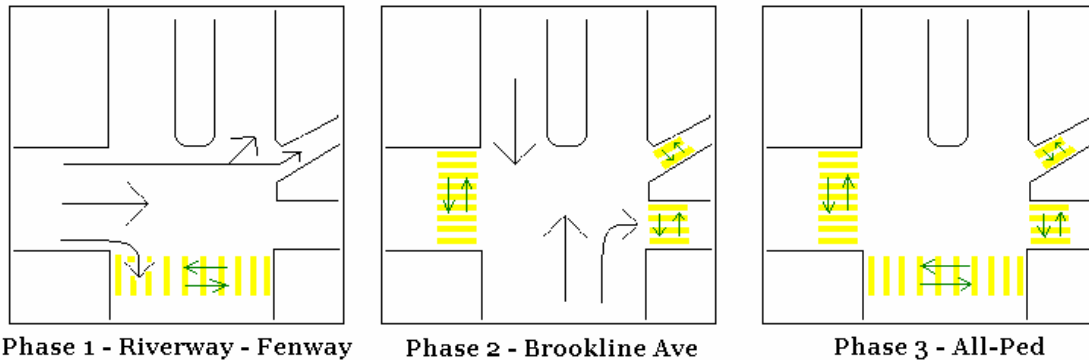


Figure 2: Phase Sequence

Pedestrians crossed after the Brookline Ave. traffic regardless of whether or not the all-ped phase occurred. Pedestrians always crossed with a concurrent phase if they could do so before the all ped phase occurred. This can sometimes cause the all-ped phase to stop all traffic with no pedestrians waiting to cross.

### **Data & Analysis:**

From the data collected, it is quite obvious why the traffic on Brookline Ave. gets backed up. When the all-ped phase is called, the Brookline Ave effective green time gets cut from 43 seconds to 18 seconds. The data also shows that the Riverway isn't affected by the all-ped phase. The dramatic cut in the Brookline Ave. effective green time is the leading cause of the back-up of traffic along Brookline Ave. heading west bound.

During the data collection, it was also noted that on average, the all-ped phase was called once every 3 cycles. From this data Brookline Ave. stands to lose 325 seconds of green time every hour. This cuts down the capacity of Brookline Ave by 23%. Without any all-ped called, Brookline Ave would receive 1720 seconds of green time per hour.

### **Solution:**

In order to fix this problem, we propose to eliminate the all-ped phase. Pedestrians can cross Brookline Ave. during the Riverway-Fenway green time. The green time for Riverway-Fenway is 42 seconds, and that's more than enough time for pedestrians to cross the 4 lanes of traffic.

The safety of pedestrians is one of our main concerns, so we analyzed the traffic flow through Brookline Ave. during the Riverway-Fenway green time. The number of

cars turning right from Riverway to Brookline Ave. west bound is only 170 veh/hr which turns out to be 4 vehicles per cycle. Given the fact that pedestrians already cross during the Brookline Ave. green time without the all-ped phase is evidence that this crossing is feasible and safe.

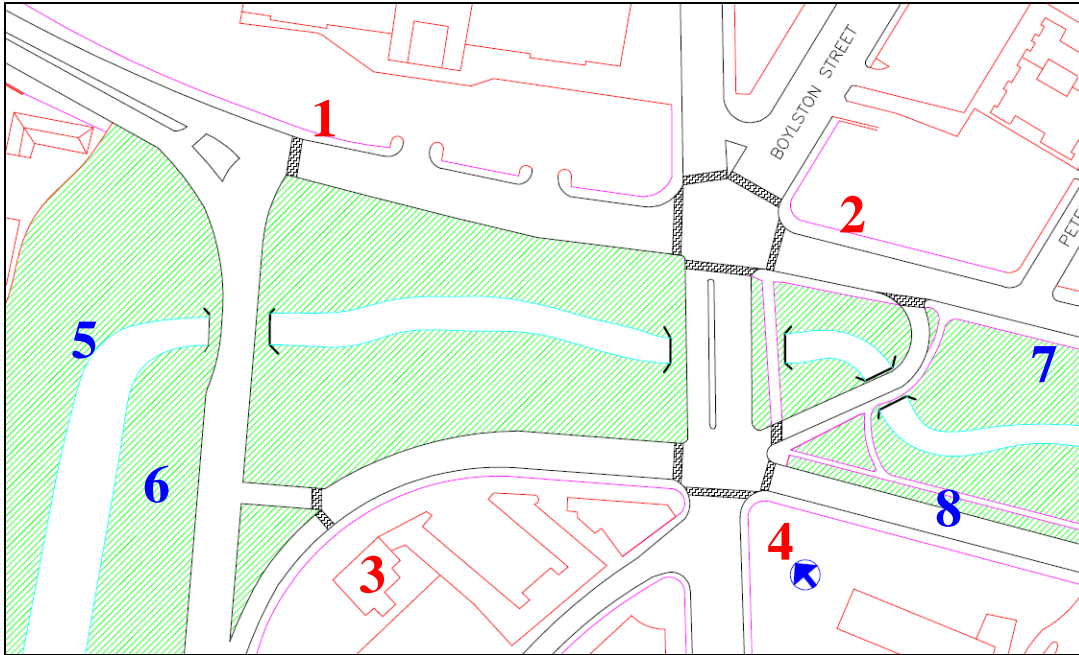
Traffic flow and the safety of pedestrians crossing Fenway during the Brookline Ave. green time was analyzed as well. Pedestrians can cross Fenway and the Jughandle during the Brookline Ave. green time. The green time for Brookline Ave. would always be 43 seconds and that's plenty of time for pedestrians to cross, which is longer than the 19 seconds that's allotted for the all-ped phase. Pedestrians complete this crossing currently without waiting for the all-ped phase.

The all-ped phase backs up traffic from Brookline Ave west bound and from data collection and analysis; we found that the all-ped phase is not needed. We propose to eliminate the all-ped phase at this intersection. The elimination of the all-ped phase won't have any effect on pedestrian crossings, and will alleviate some of the congestion on Brookline Ave west bound as well as allow Park Drive north bound cars to continue through their intersection without blockage or major congestion.

## **Pedestrian Paths and Mid-Park Bridge**

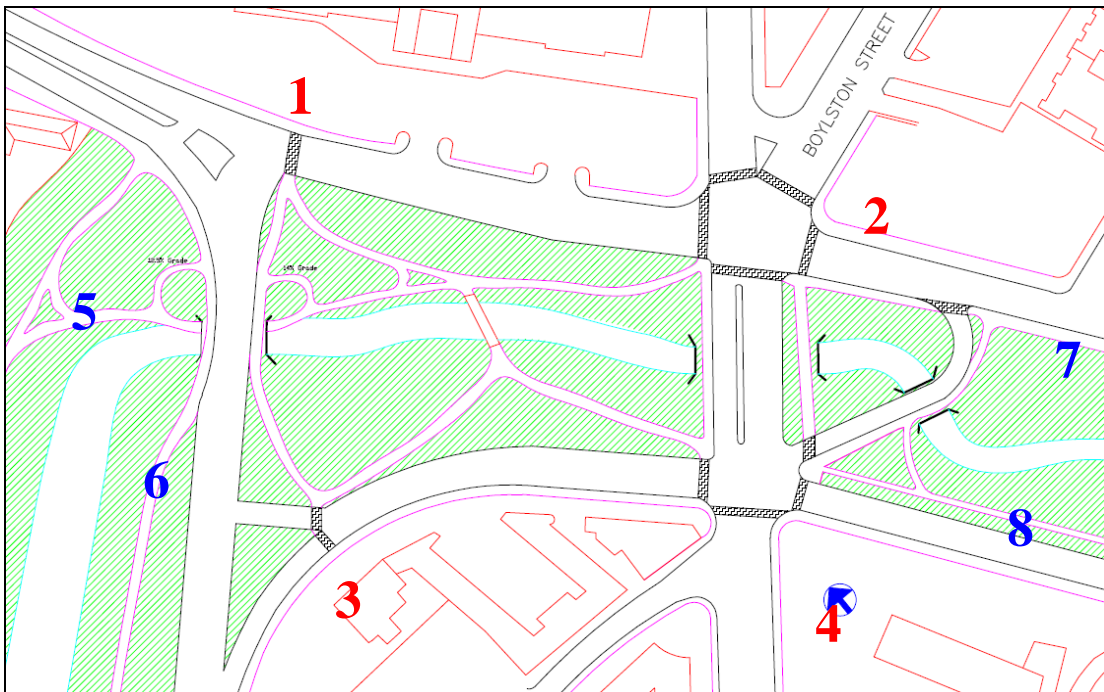
One of the main goals of this project was to determine feasible ways for pedestrians and bicyclists to get to the park and through the park. This requires a system of paths that suits the vast majority of users of the park. The park paths should be able to:

- Provide safe access to the park.
- Allow pedestrians easy access across the park. The main origins / destinations of pedestrians are:
  - 1) Fenway T Stop & Landmark Center
  - 2) Boylston Street & Fenway Park
  - 3) Wheelock College
  - 4) Longwood Medical Area
- Allow pedestrians and bicyclists to safely and effectively continue along the Muddy River Paths both upstream of the rotary (5 & 6) and downstream of the rotary (7 & 8).



Main Origins and Destinations of Pedestrians and Bicyclists

In order to accomplish these goals, the following path system was designed. All the new paths are designed to be 8-12 feet wide and asphalt paved in order to accommodate varying numbers of pedestrians and bicyclists.



Proposed Path System

One of the main components of the path system is the pedestrian bridge located in the middle of the park. Currently, this is a heavily used path that makes the connection between the Longwood Medical Area and the Fenway T Stop. The bridge would not only

provide service to pedestrians and bicyclists crossing the park, but would greatly improve the aesthetics of the park.

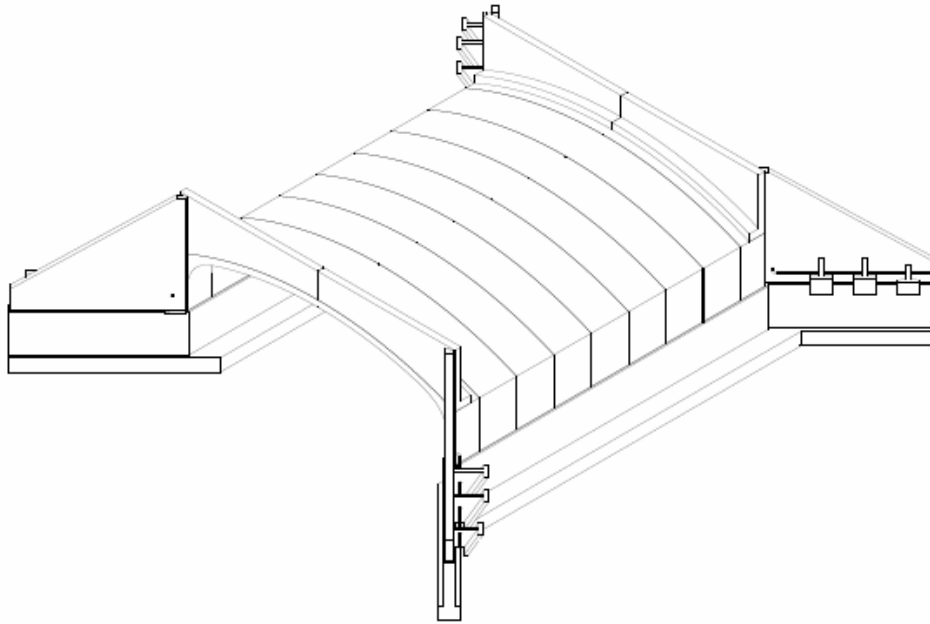


The picture above was taken of a bridge almost identical to the one in the design for the Landmark Center Park. With the addition of the bridge, the people traveling between the Landmark Center / Fenway T Stop and the Longwood Medical Area would be able to walk through the park instead of on the sidewalk next to the street, restoring one of the true purposes of the Emerald Necklace.

## **Riverway Bridge Feasibility**

A major obstacle in improving bicycle and pedestrian paths along the Muddy River is the crossing of The Riverway. The current day-lighting project being taken on by the Army Corps of Engineers consists of constructing a CON/SPAN bridge to allow The Riverway to cross over the Muddy River. We are looking at the feasibility of constructing a pedestrian and bicycle path through the underpass of that bridge. Pedestrians and bicyclists must be able to pass under the Riverway on a raised path next to the river. To construct an underpass with a pedestrian and bicycle path, an adjustment to the elevation of the existing roadway would be necessary.

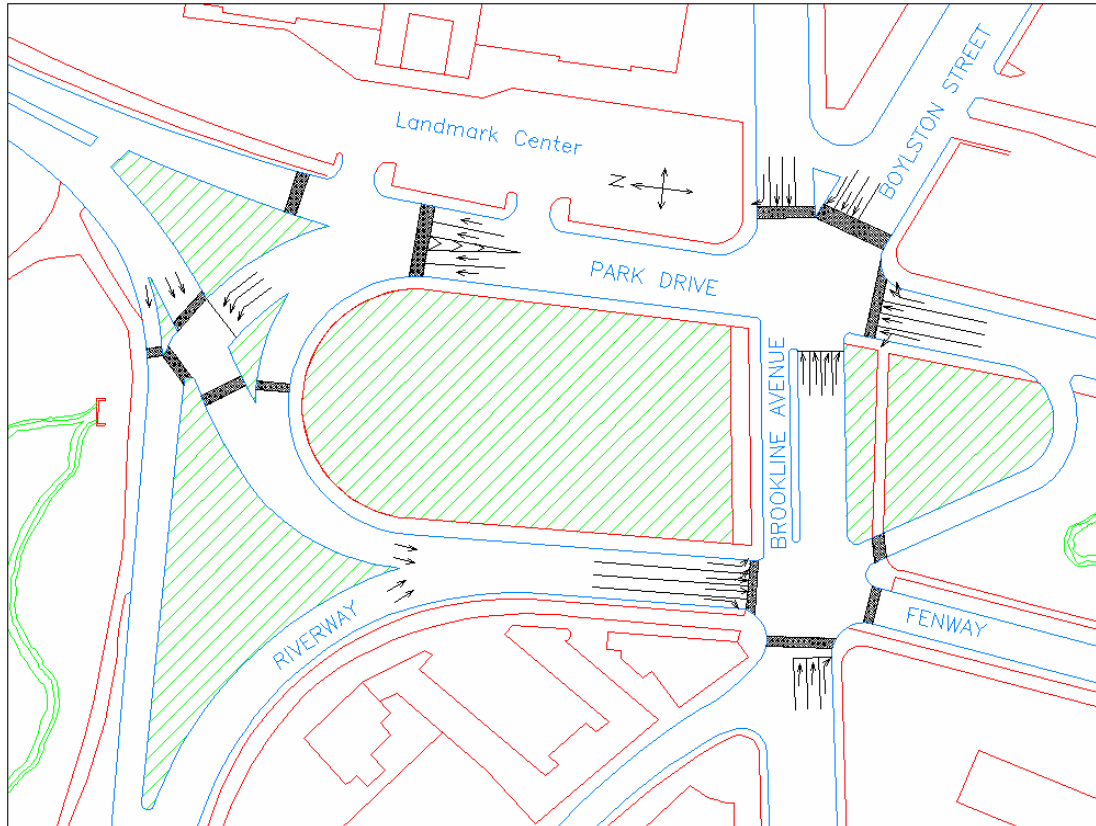




**Figure 1** – CON/SPAN bridge structure

#### **Current Bike and Pedestrian paths**

The current bike and pedestrian paths along the Muddy River are not continuous throughout the Emerald Necklace. A break occurs at the Landmark Center Rotary where there are paths upstream and downstream of the rotary, yet no paths going through the rotary itself. Figure 2 shows the current layout of the rotary with no pedestrian paths going through.

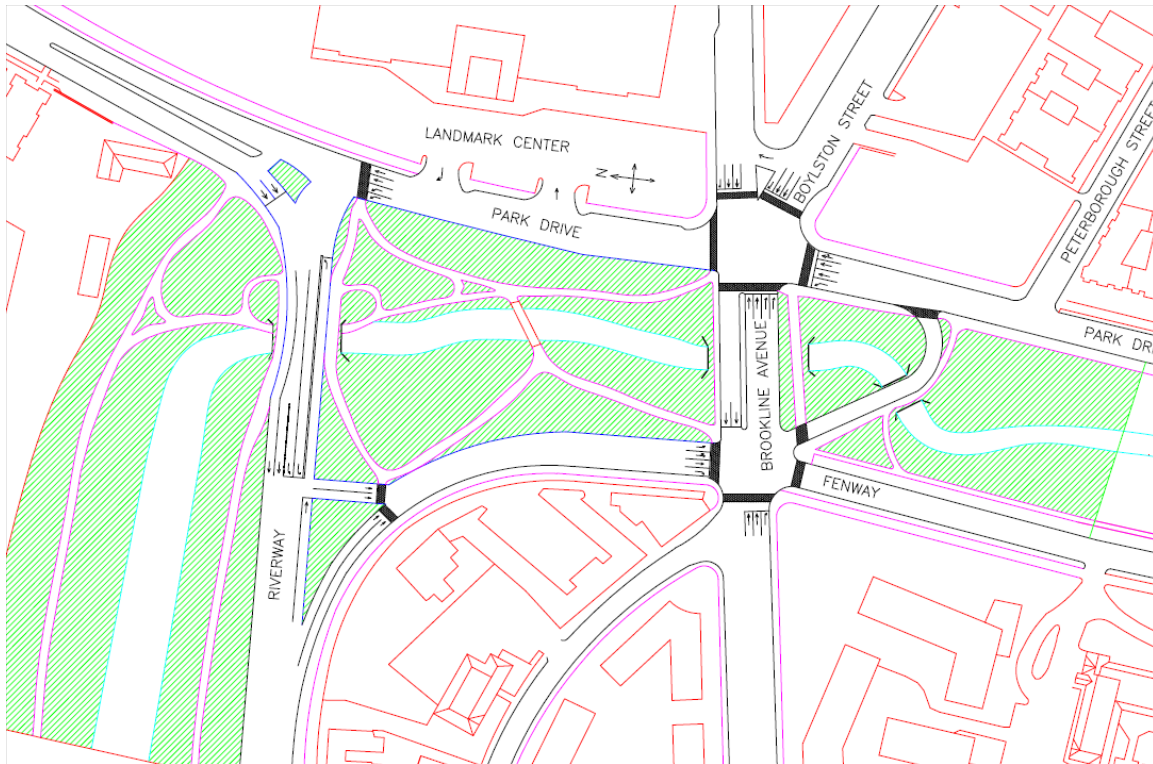


**Figure 2** – Current paths along the Muddy River

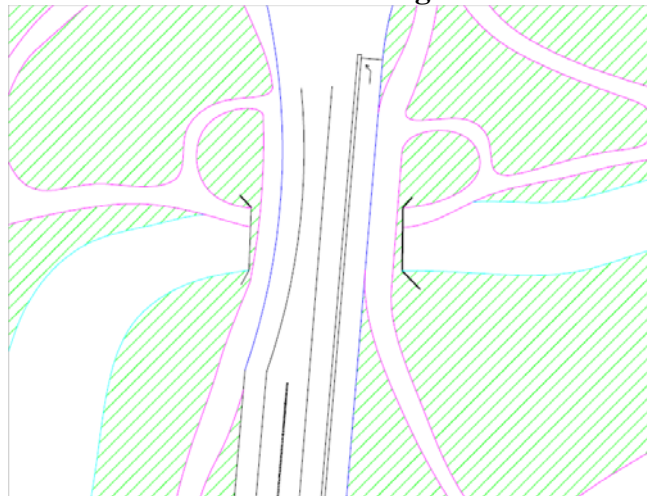
The preferred path upstream of The Riverway (to the north in Figure 2) is on the Brookline bank and is paved with asphalt instead of a clay and gravel mix which makes up the composition of the path on the Boston bank. The paths downstream of the rotary are similar on both sides of the river, so there is no preferred path. In order to create a desirable, continuous path, there needs to be a connection from the Brookline bank upstream of the rotary to the paths on either side of the Muddy River downstream of the rotary.

Figure 2 also shows that crossing The Riverway is currently a tough task. Pedestrians and bikers must go through a 4-stage crossing in order to safely cross the street. This takes a lot of time and effort, and should be done in a more efficient manner. When the day-lighting of the pond takes place, this crossing must be fixed so that bikers and pedestrians can conveniently cross The Riverway and follow a path along the Muddy River.

To enable bikers and pedestrians to cross The Riverway safely, we have designed a new layout for the rotary. This layout is called ‘The Sandal’ and includes a pedestrian underpass through The Riverway Bridge. This layout is shown with a pedestrian path that connects the upstream and downstream paths. In this design, the path follows the day-lighted river and enters the underpass on the east side and connects directly to the preferred path on the Brookline bank upstream of The Riverway. This is shown more clearly in figures 3 & 3.1:

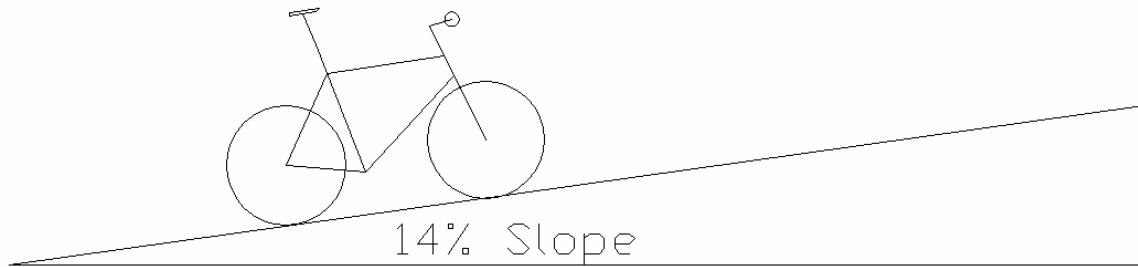


**Figure 3-** Pedestrian path through rotary



**Figure 3.1 –** Pedestrian path through underpass

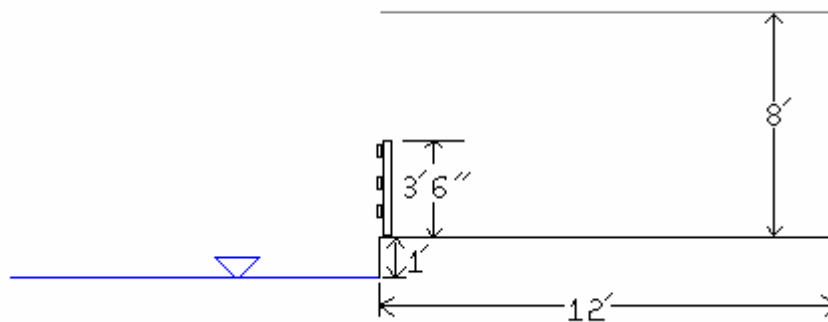
The paths in figure 3.1 that connect the pedestrian underpass to the paths at street level along the Riverway, have a slopes of 12.5% to the north of the Riverway and 14% to the south. These paths are primarily for pedestrians and bicyclists, but are not ADA accessible; however people with disabilities would be able to use the slightly longer routes that have less of a slope. To get a better idea of the grade of these paths, figure 3.2 shows a graphical representation of the slope.



**Figure 3.2**

**Bike and Pedestrian path dimensions**

The bike and pedestrian path is going to be 12 feet wide with an overhead clearance of 8 feet, which is the bike path standard. The path will be 1 foot above the river elevation. This distance of 1 foot will allow the path to be used during most storms that will cause a slight rise in the waterline. After the current day lighting project, a rise of one foot would only occur in a 5 year storm or greater. In order to keep the elevation of the Riverway as low as possible, we decided to design for the 5 year flood. A 3 foot 6 inch railing will be placed at the edge of any walkway next to the water. All of these dimensions are shown in the figure below, figure 4;



**Figure 4 – Pedestrian path dimensions**

Currently, a pedestrian path with an 8 foot clearance would not fit through the underpass of the Riverway bridge. The roadway elevation would have to be raised approximately 3 feet. The current underpass would also cover a distance of 185 feet if no roadway improvements were made to Riverway-Park Drive. In our Sandal layout, as shown in figure 3, the underpass length would be decreased to approximately 72 feet. Even if an underpass is not put in, the minimizing of this distance makes crossing The Riverway safer at grade.

**Roadway elevations and profiles**

The current roadway would have to be raised 3 feet at the peak of the bridge in order to accommodate the pedestrian path through the underpass. Figure 5 shows a profile with the current elevation of The Riverway and the proposed elevation with the bridge underpass. The proposed roadway elevation will meet the existing elevations at

points 'A', 125 feet to the west of the bridge peak and point 'C' 175 feet to the east of the bridge peak. The bridge peak is located at point 'B'.

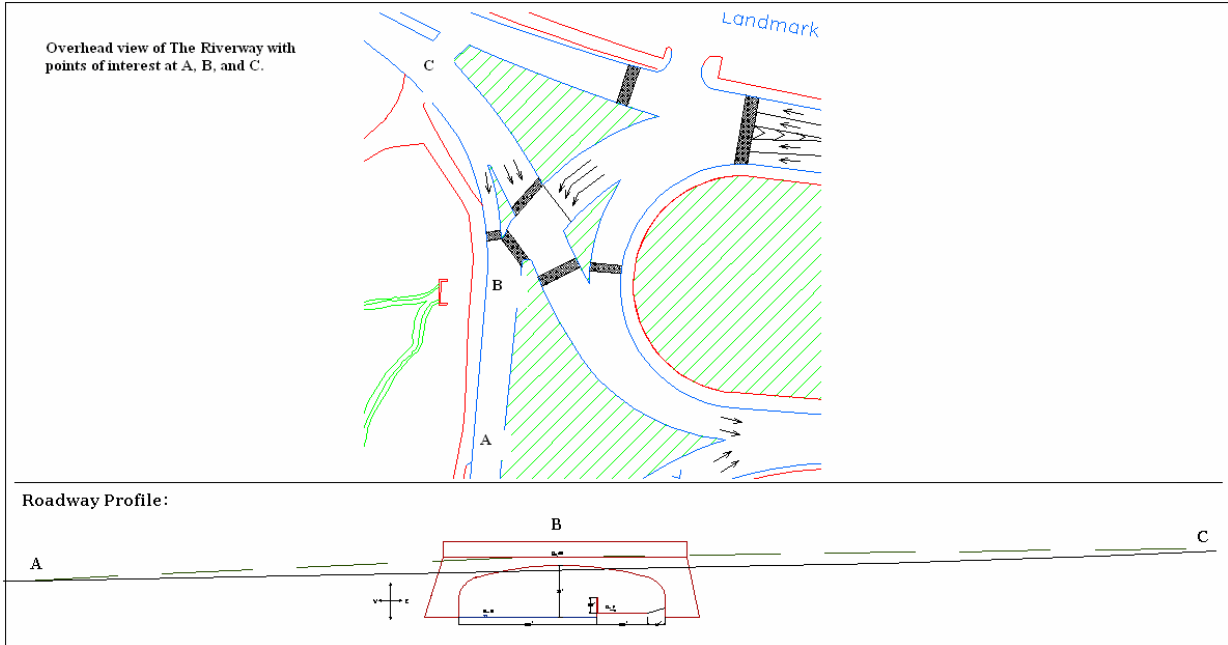
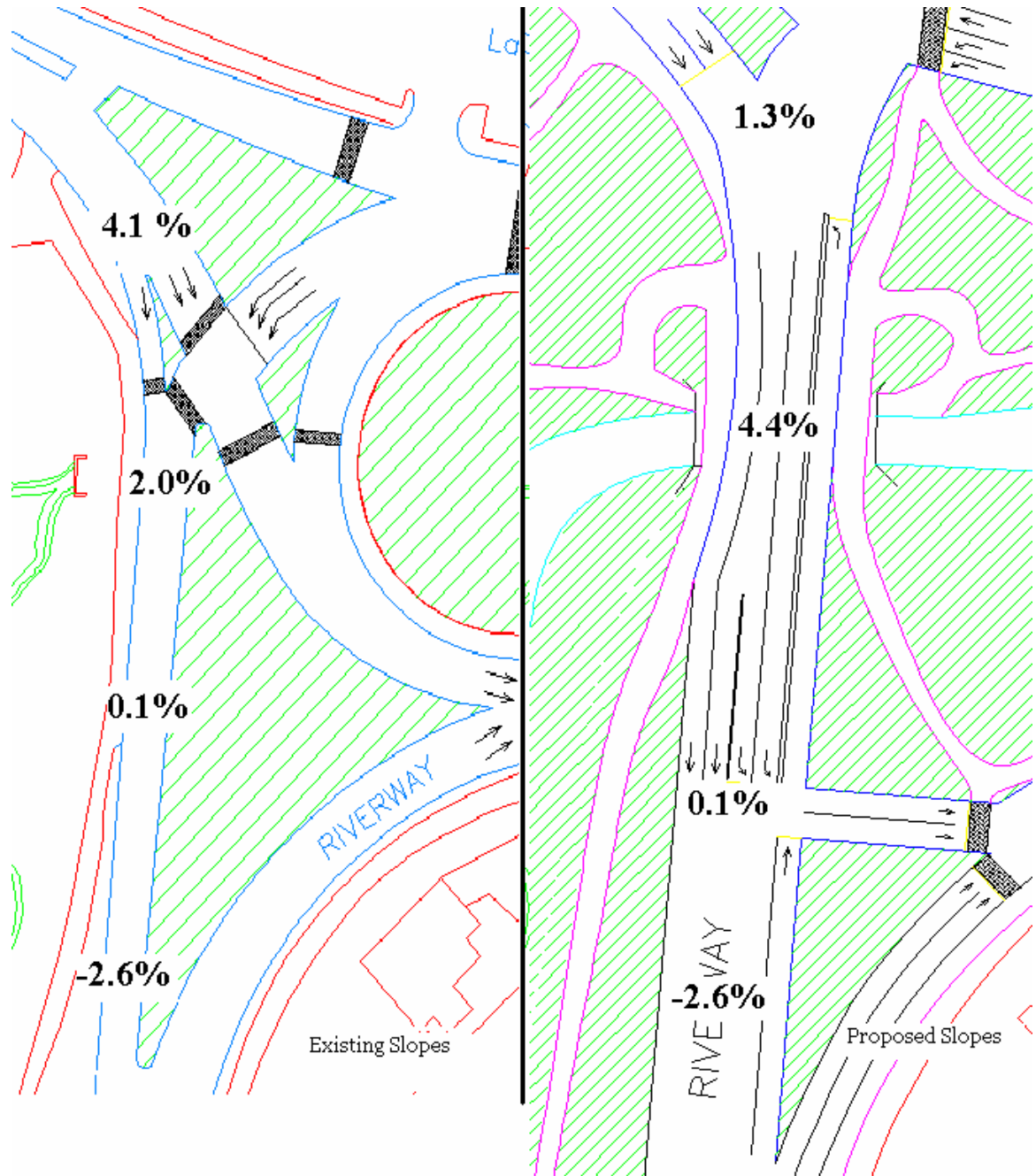


Figure 5 – Roadway profile

In this figure, the intersection of the proposed with the existing profile to the east of the underpass (Point C) is at an elevation of 24.34 feet. The elevation of the proposed roadway at the peak of arch is at an elevation of 22 feet (Point B) and the elevation at the west intersection (Point A) is 16.49 feet. Currently, the elevation at point B, is 18 feet 10 inches, causing the new elevation at the peak to be approximately 3 feet higher.

The raising of The Riverway will not have a dramatic impact on the grade. Figure 6 shows the existing grades compared to the proposed grades.

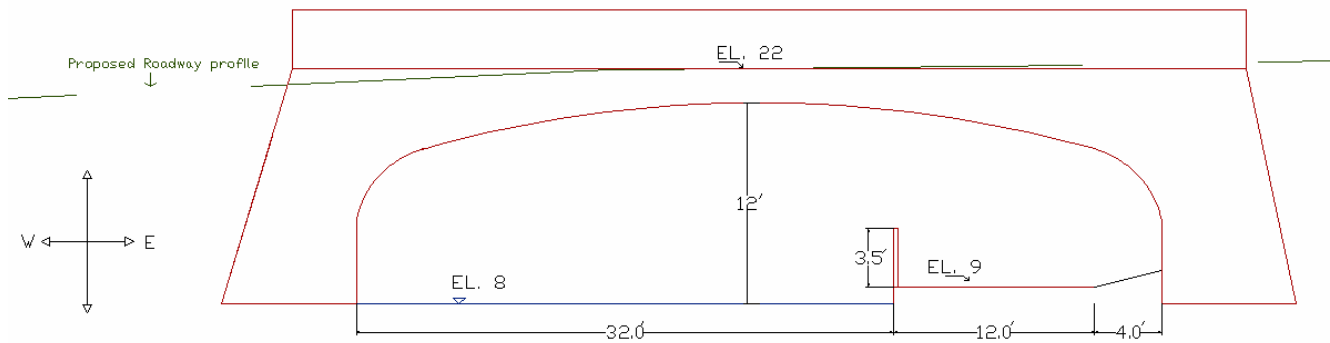


**Figure 6** – Existing grades along The Riverway

When comparing these layouts, the biggest grade change is 2.8% to the east of the underpass. The change in grade on the west side of the underpass is 2.2%. As shown in figure 6, the change in elevation would simply push the slope of 4% further west and closer the Riverway-Park Drive merge.

**Cross Section:**

Our design for the Riverway Bridge includes a CON/SPAN structure to span 48 feet with the pedestrian walkway entering through underpass on the East bank. A detailed cross-section of the underpass with the pedestrian path is shown in figure 7.



**Figure 7 – Underpass cross-section**

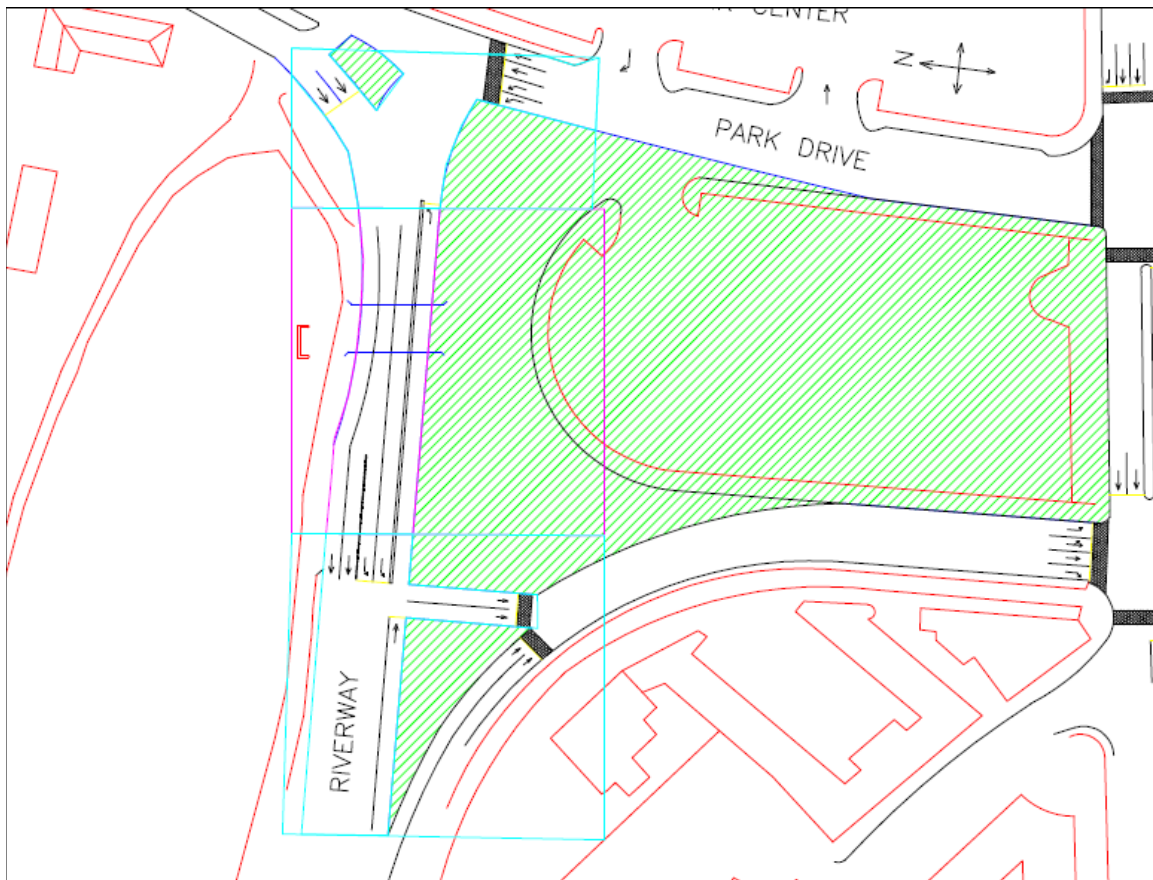
We were informed by a CON/SPAN consultant to use a bridge that spans 48 feet in order to get the proper clearance off the bike path. CON/SPAN also recommended going with a rise of 12'. In figure 7, it is shown that with a rise of 12 feet, and a bridge and road thickness of 2 feet, the elevation of the road would be 14 feet above the river which has an elevation of 8 feet during normal conditions.

### **Conclusion:**

We feel that it is feasible to put a pedestrian path through the underpass of The Riverway Bridge. The Riverway would only have to be raised approximately 3 feet to accommodate the path and the proposed new grade would also create a smoother roadway profile for traffic. Constructing a pedestrian path through the underpass would help to alleviate some of our main problems in the rotary. This path would connect the existing upstream and downstream paths while also keeping the bikers and pedestrians away from traffic.

### **Cost Estimate**

After analyzing the current layout of the Landmark Center Rotary and distinguishing between the proposed roadways, paths, crosswalks, lane markings, signals and bridges from The Sandal plan, we were able to come up with estimates on the total cost it will take to install these new features. Because the Army Corps of Engineers have designed a layout for day lighting the Muddy River in certain areas of the park, we have taken into account that they will be responsible for all cut and fill and elevation changes to the Landmark Center park area. Since we have no access to the Army Corps's actual plans of day lighting the Muddy River, we have assumed that they are not changing any roads or paths. Another assumption we are making is that we are not changing the layout of the parks, such as elevations or grade changes. We have assumed the amount of roadway the Army Corps will be removing and replacing as about 23,215 square feet. From our design, in the same area as the Army Corps will be working on excavating and replacing the roadways, we will be using a smaller area of roadway to conduct this performance by using only 13,100 square feet. Please see the marked areas below from the existing layout and from The Sandal layout to distinguish the difference in areas of roadways.



In order to develop estimates for The Sandal's roadways, paths, crosswalks, lane markings, signals and bridges, we looked at the unit costs of the materials specific for each design. From the unit costs, we were able to determine the total amount it would cost to install each of these aspects of our design. From talking with Bob Grover, Director of Stoneham DPW/Town Engineer, we were able to estimate that it costs \$2.25 per square yard to excavate a current roadway. To prepare the sub-base by grading, it will cost about \$2.50 per square yard. For the paving asphalt, the binder course which would be about 2" thick would cost \$5 per square yard as well as the top course at 1" thick. From these unit costs, the amount of roadway we are proposing brings the total amount to about \$38,000 while accounting for 20% of engineering and contingency work.

Taking into account our proposed pathway system, we had to find the total cost it would take to construct the paths. Also from talking with Mr. Grover, we found that for preparation and construction, it would cost about \$12 per square yard for 3" thick paths. From our design, we have a total of 1,940 feet of proposed 12 foot wide shared paved paths which will equal about \$31,040 to install.

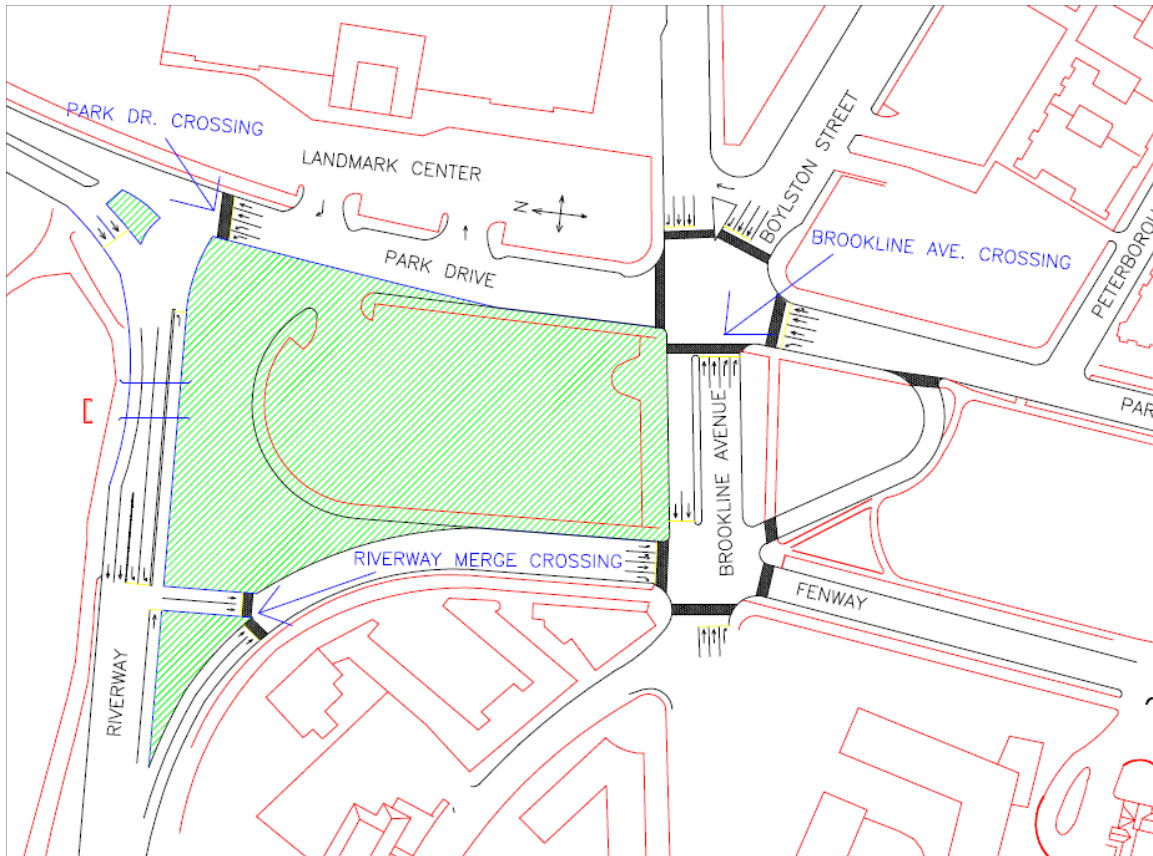
Using the formula:

$$0.062172 * \text{Thickness (in.)} * \text{Area (square yards)} = \text{Asphalt Yield (Tons)}$$



we were able to determine the amount of asphalt needed to design the roadways and paths. By using a 2.5" thickness, we determined that we would be using about 227 tons of asphalt for the roads and about 402 tons for the paths.

With The Sandal plan, we will be adding three new crosswalks. The new crosswalks are located at the Brookline Ave intersection, Park Drive crossing and the Riverway merge (please see below for exact locations). Crosswalks cost about \$20 per linear foot to install. For the Brookline Ave crossing, it will cost about \$1,560 to put in. It will cost about \$880 to install the Park Drive crossing and about \$960 for the Riverway merge crossing.



Using striping with fast-drying paint for lane markings usually costs about \$0.07 per linear foot in urban areas.

According to our proposed design of The Sandal, we are replacing traffic signals at 4 intersections. It costs about \$130,000 to buy and install traffic signals at each intersection. Therefore, our cost for adding the 4 new signals would be \$520,000.

At the Boylston Street and Park Drive intersection, a bulb-out has been added on the Boylston Street side of the road to allow a shorter distance for pedestrians and bicyclists to cross Boylston Street. This does not affect the traffic in any way because there is enough lane usage for motorists to travel to their destinations. The cost for adding this bulb-out is very minor. To remove curb, it costs about \$7 per linear foot. We will be removing about 63 feet of curb making the total amount to be about \$440 to add the bulb-out.

Finally, the two added bridges that are located crossing the soon to be day lighted Muddy River in the Landmark Center Park and across The Riverway add to the final cost of our design. After contacting a representative from CONSPAN, the bridge that will cross the Muddy River in the middle of Landmark Center Park will cost approximately \$41,000. We received an estimate for the Riverway bridge that we propose to account for our pedestrian underpass. CON/SPAN estimated the bridge at approximately \$228,000, which we conclude is approximately only \$28,000 more expensive than what the Army Corps plans on using.

The total amount for all of the work that we propose in addition to what the Army Corps has planned is approximately \$790,000. If we were to completely take control and take over the bridge cost and total rotary reconstruction, our estimate would be \$1.1 million.

## Conclusion

At the beginning of this project, it was our objective to address several areas of concern relating to the Landmark Center Rotary. There was a need to improve the pedestrian and bike access to the park in the middle of the rotary as well as improve the path system along the Muddy River. We also wanted to improve traffic flow throughout the rotary while reconnecting the park to the rest of the Emerald Necklace.

The proposed re-design of the rotary accomplishes all of these goals. The interior pedestrian crossing at the Brookline Ave-Boylston-Park Drive intersection facilitates pedestrians and bikers into the rotary. Before there was no interior crossing to get into the park from the downstream paths. Pedestrian and bike traffic also benefit from the pathway underpass at the Riverway bridge. This underpass allows bikers and pedestrians to safely cross the Riverway without having to worry about traffic or make their way through a 4 stage crossing.

The path system will greatly improve pedestrian access to and through the park. Pedestrians are now given direct paths from the Fenway T-stop to Wheelock College and the Longwood Medical Area. There are also paths along the Muddy River that allow pedestrians and bikers to enjoy nature and use the park as Frederick Olmsted intended. These paths also connect the park to the rest of Boston's Emerald Necklace.

Traffic in the rotary will see better flow and less congestion due to some of the proposed improvements. Connecting Riverway east bound to Park Drive north bound will keep some cars out of the Brookline Ave-Boylston intersection, as well as give those motorists an easier route to get from their origin to their destination. Another proposal that will help traffic flow improve is the elimination of the all-ped phase at the Brookline Ave-Fenway intersection. Since the pedestrians do not need this to safely cross either Brookline Ave or the Fenway, the extra green time will help alleviate the congestion on Brookline Ave. The proposed synchronization of the traffic lights in the rotary will also serve as a traffic improvement. The average level of service of the rotary is up from a C to a B.

We believe that the proposed design has met the challenges associated with the area and that all of the objectives have been satisfied. Both pedestrian and vehicular uses will be greatly improved. After the reconstruction detailed in this report, the park will hopefully once again be used as it was designed in the eyes of Fredrick Olmsted himself.