

**Measuring the Vibrations of a Thin, Tensioned Magnetic Tape Using a Polytech
Vibrometer**

by

Heath Marvin

Northeastern University
Department of Electrical and Computer Engineering
Boston, MA 02115

A research report for

Independent studies

(Prof. S. Müftü, Department of Mechanical & Industrial Engineering)

&

Electromagnetic Fields and Waves, Honors Adjunct

(Prof. M. Silevitch, Department of Electrical and Computer Engineering)

December 2004

Table of Contents

| | |
|---|----------|
| Introduction | 1 |
| Experimental Procedure | 2 |
| Results | 2 |
| Conclusion | 3 |
| Appendix A | 4 |
| Setting up LabView to Measure Frequencies | 4 |
| Setting Up Fixed Tape for Displacement Measurement..... | 5 |
| Appendix B | 6 |

Introduction

The goal of our experiment was to find the harmonic frequencies of a tape with fixed ends and different tensions. See Figure 3 in the appendix for set-up. The formula used for vibrations of a tensioned string is as follows:

$$T \frac{\partial^2 w}{\partial x^2} = m \frac{\partial^2 w}{\partial t^2} \quad (1)$$

where T is tension, m is mass/length, w is out of plane displacement of the string, x is the longitudinal coordinate placed on the string, and t is time. In our experiment the string is supported by a distance, L, apart. The boundary conditions then are,

$$\begin{aligned} \text{at } x=0 \quad w(0,t)=0, & \quad \text{a)} \\ \text{at } x=L \quad w(L,t)=0 & \quad \text{b)} \end{aligned} \quad (2)$$

Using the method of separation of variables, equations (1) and (2) can be shown to have the following solutions [Habermann R. Elementary Applied Partial Differential Equations Journal of Sound and Vibration, 2nd Ed. Prentice-Hall, 1987]

$$w(x,t) = A_1 \sin\left(\frac{n\pi}{L}x\right) \sin\left(\frac{cn\pi}{L}t\right) + A_2 \sin\left(\frac{n\pi}{L}x\right) \cos\left(\frac{cn\pi}{L}t\right), n = 1, 2, 3... \quad (3)$$

Where A1 and A2 are coefficients which can be determined for specific initial conditions, and c is the transverse wave speed of the displacement w defined as,

$$c^2 = \frac{T}{m} \quad (4)$$

Equation (3) shows that the vibration frequency $f = \frac{\omega}{2\pi}$ is

$$f = \frac{1}{2\pi} \left(\frac{cn\pi}{L} \right), n = 1, 2, 3... \quad (5)$$

where n indicates different harmonics or modes of vibration. For an impact type of external loading all of the string's vibration frequencies would contribute to its response. Thus, if we could capture the tape's displacement response to such loading then we could find the fundamental vibration frequencies by taking the Fourier transform of the response.

A factor that we neglected in our first experiment was the effect of air on the vibrations. These effects were amplified by the fact that we were using an inch-wide tape. As the linear mass density of air,

$$m_{air} = \delta_{tape} (width * thickness) \quad (6)$$

the vibration of tape is expected to be affected by the presence of air [Pramila, A. (1987) “Natural Frequencies of a Submerged Axially Moving Band” Journal of Sound and Vibration, vol. 113 pp. 198-203]. In such a case it can be shown that the vibration frequencies become

$$f = \frac{1}{2\pi} \left(\sqrt{\frac{T}{m_{tape} + m_{air}}} \frac{n\pi}{L} \right), n = 1, 2, 3, \dots \quad (7)$$

Experimental Procedure

In the experiment, we measured the frequency of a tape supported by two fixed ends with three different tensions. Our measurements were done with a Polytec Vibrometer which fed it collected data into Labview where we took the Fourier Transform of the data to find the fundamental frequencies.

The set-up of our tape and the procedures for using the vibrometer and Labview can be seen in Appendix A.

Results

Tables 1-3 shows the comparison of the measured frequencies, estimated frequencies without air resistance, and the estimated frequencies with air resistance.

| | Mass (kg) | Tension (N/m) | |
|----------------|----------------------------------|-------------------------|-------------------------|
| | 0.1 | 38.62205 | |
| Vibration Mode | Estimated Frequency Eq. (5) (Hz) | Measured Frequency (Hz) | Measured Frequency (Hz) |
| 1 | 105 | 85 | 80 |
| 2 | 210 | 170 | 180 |
| 3 | 315 | 254 | 260 |
| 4 | 419 | 339 | 340 |
| 5 | 524 | 424 | 430 |

Table 1

| | Mass (kg) | Tension (N/m) | |
|---|----------------------------------|----------------------------------|-------------------------|
| | 0.2 | 77.24409 | |
| | Estimated Frequency Eq. (5) (Hz) | Estimated Frequency Eq. (6) (Hz) | Measured Frequency (Hz) |
| 1 | 148 | 120 | 110 |
| 2 | 297 | 240 | ? |
| 3 | 445 | 360 | 350 |
| 4 | 593 | 480 | 410 |
| 5 | 742 | 600 | ? |

Table 2

| | Mass (kg) | Tension (N/m) | |
|---|---|---|--------------------------------|
| | 0.05 | 19.31102 | |
| | Estimated Frequency Eq. (5) (Hz) | Estimated Frequency Eq. (6) (Hz) | Measured Frequency (Hz) |
| 1 | 74 | 60 | 60 |
| 2 | 148 | 120 | 110 |
| 3 | 222 | 180 | 200 |
| 4 | 297 | 240 | 270 |
| 5 | 371 | 300 | ? |

Table 3

See full results in Appendix B.

The question marks in the measured frequency column are due to our inability to determine from the graphs these frequencies. This difficulty may have been due to our method of external loading. We tried to induce vibrations by a sharp, quick tap (an impulse), but this was not perfect, and there was probably some vibration in the supports which influenced the tape's vibration.

Conclusion

These experiments were very useful in understanding the wave and frequency properties of a vibrating string and learning to use the vibrometer and Labview. As can be seen in the results, our results were significantly affected by including air density in our calculations. This brought our results much closer to the actual, measured data.

Appendix A

Setting up LabView to Measure Frequencies

The LabView computer connects to the Polytec Vibrometer with a BNC connector. It is connected from the Displacement Output port on the Vibrometer to the BNC input on LabView (this BNC input may need to be installed, but this is a simple process).

Once the Vibrometer is set up and ready to measure and connected to LabView, open National Instruments LabView 7.0 on the LabView computer and follow these steps:

- In the first window, click New
- In the New dialog box, under VI from Template, DAQ, click Data Acquisition with NI-DAQmx.vi
- Click OK

Now you have a new block diagram. For data acquisition, you will want a final design that looks something like Figure 1. Follow the steps in Figure 1 to acquire data, take the FFT of the data, and write both the raw and FFT data to separate files.

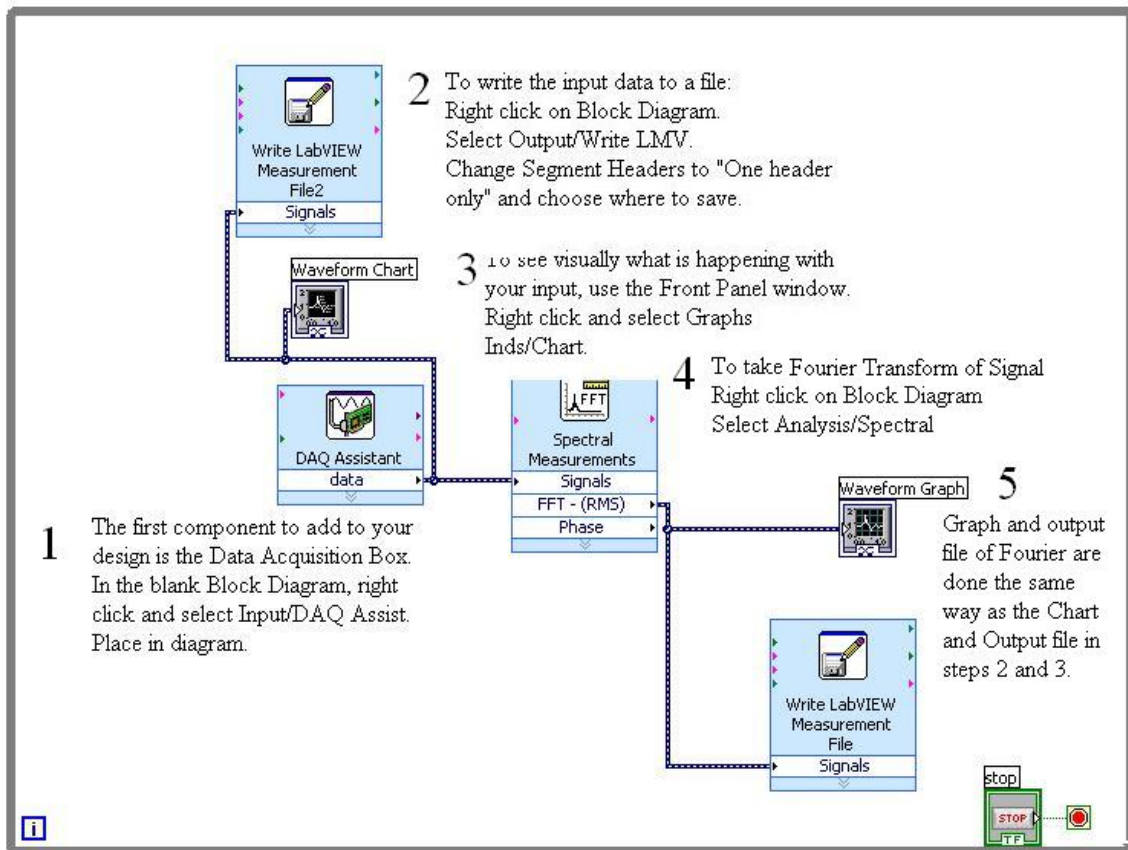

Figure 1: Block Diagram of Data Collection

The "Front Panel" referred to in Figure 1 can be seen in Figure 2.

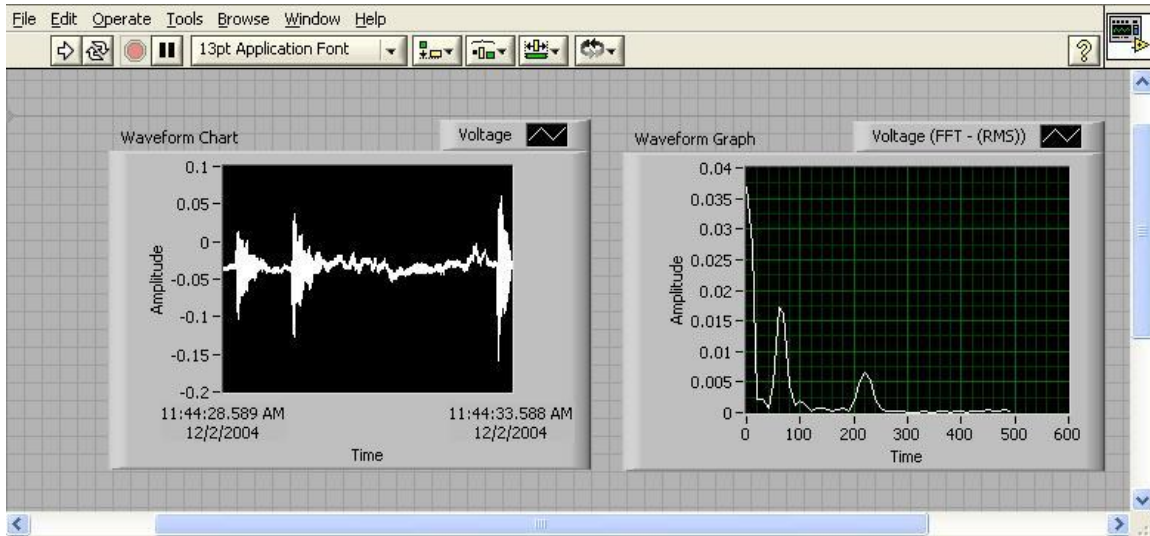

Figure 2: Front Panel showing displacement and FFT of displacement

Setting Up Fixed Tape for Displacement Measurement

Figure 3 shows the basic set-up that was used to measure the displacement of the tape.

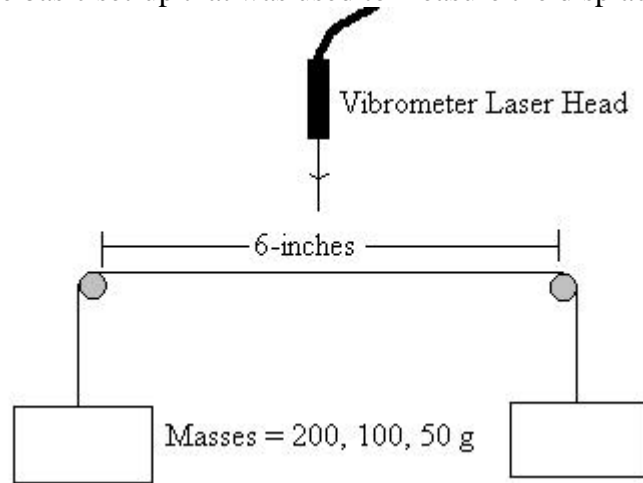

Figure 3: Set-up of fixed tape

Appendix B

| Mass (kg) | Width of Tape (m) | Thickness of tape (m) | Force (N) | |
|------------------------------|-------------------------------------|-----------------------|---------------|-----|
| 0.05 | 0.0254 | 2.70E-05 | 0.4905 | |
| Density (kg/m ²) | Volume Density (kg/m ³) | Support Distance (m) | Tension (N/m) | |
| 0.0378 | 1400 | 0.1524 | 19.31102362 | |
| n | wave speed (m/s) | | | |
| | 22.60251404 | | 18.28214564 | |
| | Frequency (Hz) | | | |
| | calculated w/o air | calculated w/ air | measured | |
| | 1 | 74.2 | 60.0 | 60 |
| | 2 | 148.3 | 120.0 | 110 |
| 3 | 222.5 | 179.9 | 200 | |
| 4 | 296.6 | 239.9 | 270 | |
| 5 | 370.8 | 299.9 | ? | |

Table 4: Tape Properties with Mass of 50 g and Estimated Frequencies

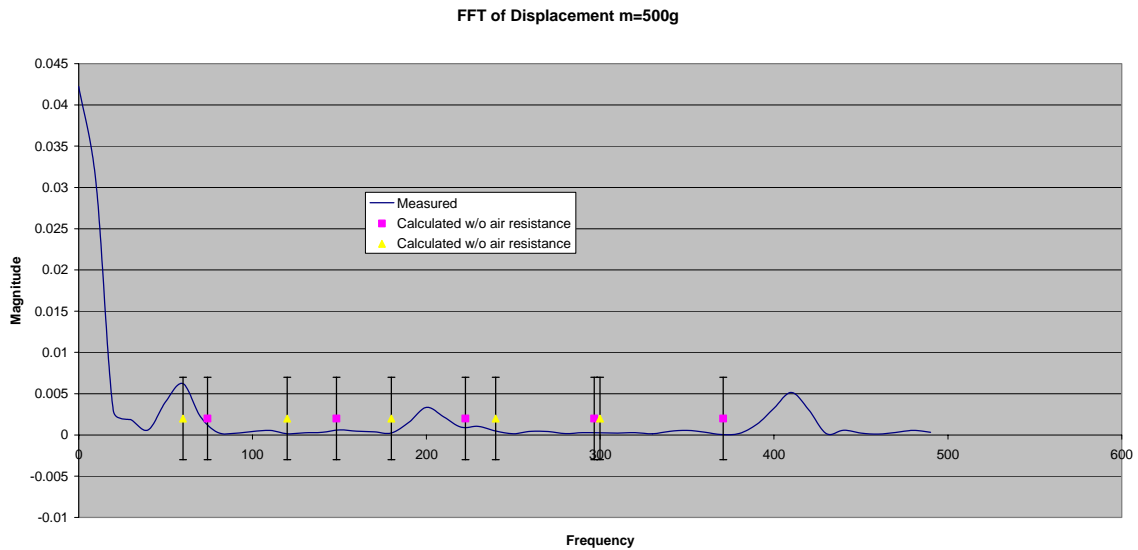

Figure 4: Fourier Transform of Displacement with Mass of 50 g

| Mass (kg) | Width of Tape (m) | Thickness of tape (m) | Force (N) | |
|------------------------------|-------------------------------------|-----------------------|------------------|-----|
| 0.1 | 0.0254 | 2.70E-05 | 0.981 | |
| Density (kg/m ²) | Volume Density (kg/m ³) | Support Distance (m) | Tension (N/m) | |
| 0.0378 | 1400 | 0.1524 | 38.62204724 | |
| n | wave speed (m/s) | | wave speed (m/s) | |
| | 31.96478189 | | 25.85485831 | |
| | Frequency (Hz) | | | |
| | calculated w/o air | calculated w/ air | measured | |
| | 1 | 104.9 | 84.8 | 80 |
| | 2 | 209.7 | 169.7 | 180 |
| 3 | 314.6 | 254.5 | 260 | |
| 4 | 419.5 | 339.3 | 340 | |
| 5 | 524.4 | 424.1 | 430 | |

Table 5: Tape Properties with Mass of 100 g and Estimated Frequencies

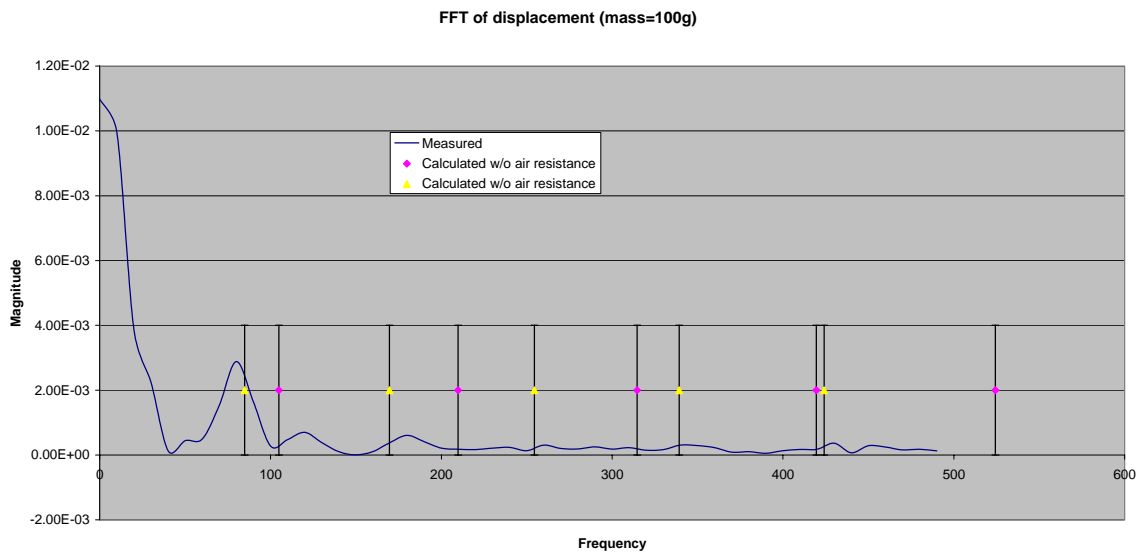

Figure 5: Fourier Transform of Displacement with Mass of 100 g

| Mass (kg) | Width of Tape (m) | Thickness of tape (m) | Force (N) | |
|------------------------------|-------------------------------------|-----------------------|---------------|-----|
| 0.2 | 0.0254 | 2.70E-05 | 1.962 | |
| Density (kg/m ²) | Volume Density (kg/m ³) | Support Distance (m) | Tension (N/m) | |
| 0.0378 | 1400 | 0.1524 | 77.24409449 | |
| n | wave speed (m/s) | | | |
| | 45.20502807 | | 36.56429128 | |
| | Frequency (Hz) | | | |
| | calculated w/o air | calculated w/ air | measured | |
| | 1 | 148.3104596 | 119.9615856 | 110 |
| | 2 | 296.6209191 | 239.9231711 | ? |
| 3 | 444.9313787 | 359.8847567 | 350 | |
| 4 | 593.2418382 | 479.8463423 | 410 | |
| 5 | 741.5522978 | 599.8079279 | ? | |

Table 6: Tape Properties with Mass of 200 g and Estimated Frequencies

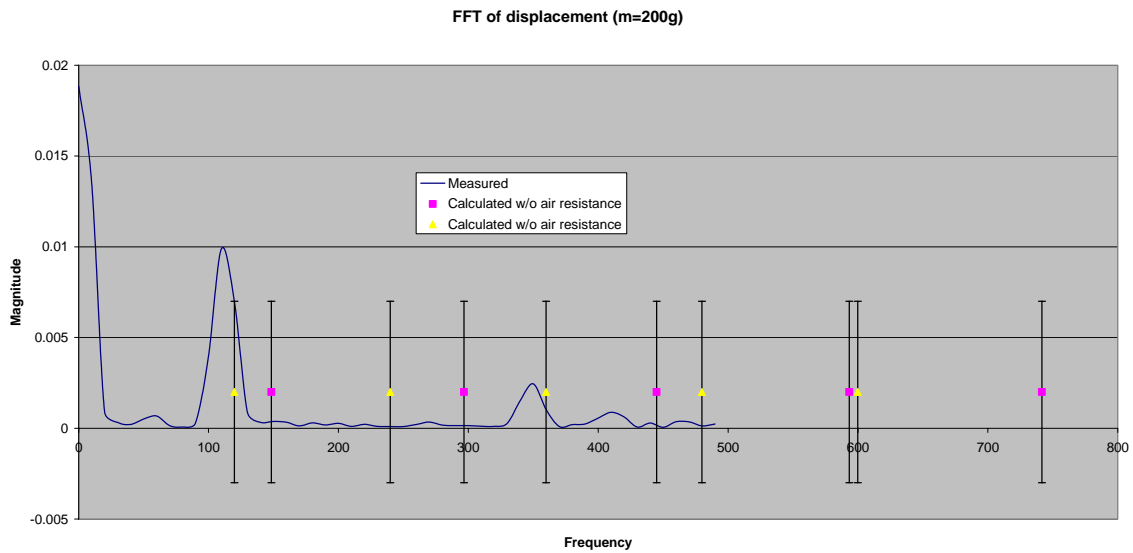

Figure 6: Fourier Transform of Displacement with Mass of 200 g